

# Shower with heat recovery.

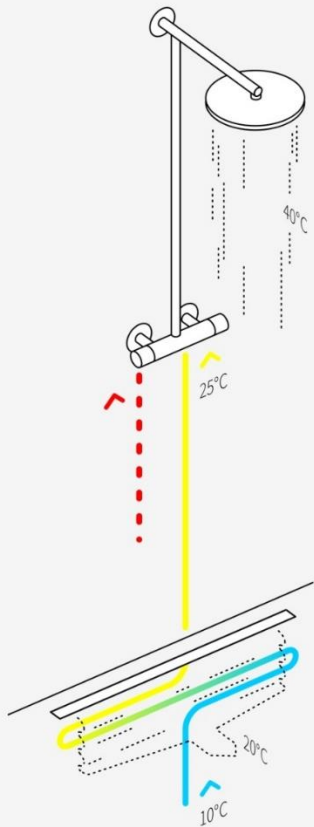

The cold water supply is connected directly to the upstream **heat exchanger**. The **waste energy** of the used shower water **pre-heats the incoming cold water**, which reaches the mixing valve already warmed, so less hot water from the boiler is needed to enjoy a relaxing warm shower. The Joulia heat exchangers recover up to 63% of wasted heat.

Internationalisation:  
Received german drinking water certification (DVGW) → new markets DE/AT

Passivhaus-Certification: highest efficiency

Expansion

- +40% growth in NL with existing partner
- new: Belgium, Luxembourg
- product developments with



joulia  
HEAT EXCHANGERS  
FROM SWITZERLAND

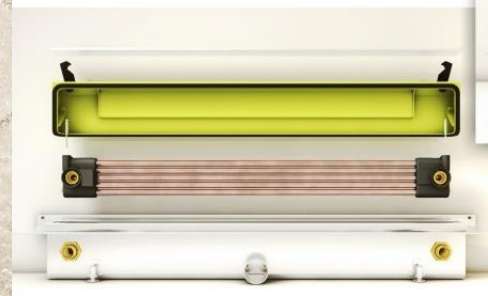

**Pitch Deck for Energy Startup Day 2021**

4.11.2021 - Claudio De Giacomi, Environmental Engineer BSc, [claudio@joulia.com](mailto:claudio@joulia.com)

Copyright by Joulia ltd., Zentralstrasse 115, 2503 Biel-Bienne, Switzerland.